

3	横向加强筋	340*60*5	热镀锌板	3
2	挂钩	145*70*R25*8	热镀锌板	4
1	踏板本体	2308*350*60*1.8	热镀锌板	1
序号		名称	尺寸	材料
备注		带安全锁扣		
数量		Hefei LP 合肥轻工		
共张		脚手架		
张		Scaff Panel Total Unit		

## Scaffolding Boards General Specifications

1. The products are widely used in architecture industry for worker motion while on scaffolding;
2. They are metal constructure, made up with noumenon (part 1), end-covers (part 2), ribs (part 3); sometimes also with fitting hooks (part 4);
3. The following standard items for client selection; OEM also workable.

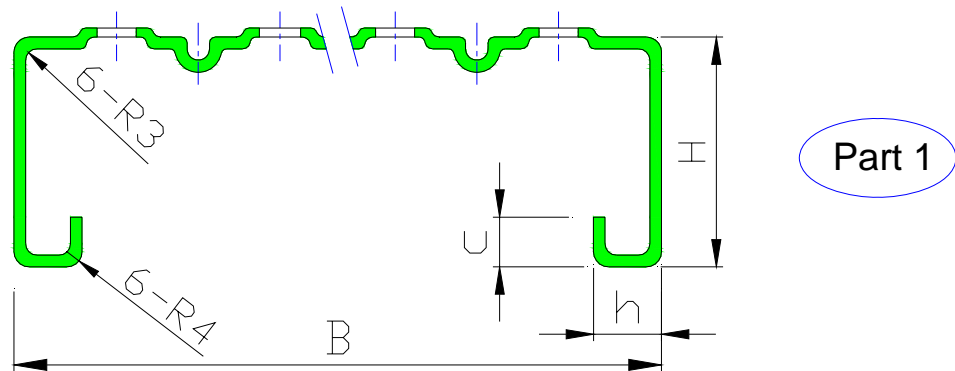

NO.	Noumenon section B*H*h*c (MM)	Material thickness (MM)	Hook Arc Dia. (MM)
1	210*45*20*15 (Japaness)	1.2	42.5 or 48
2	228*75*20*15 (Euro)	1.8	48
3	228.6*63.5*20.5*14.5 (USA)	1.6 or 1.8	48
4	230*60*25*10 (Australia)	1.5 or 1.8	
5	240*38*20*15 (Japaness)	1.2 or 1.5	
6	240*45*20*15 (Japaness)	1.2 or 1.45	
7	250*40*20*15 (Japaness)	1.2 or 1.5	
8	240*45*20*15 (Both)	1.2 or 1.45	42.5 or 48
9	295*90*20*15 (Euro)	1.5 or 1.8	"U"shape 48
10	300*50*20*15 (Japaness)	1.2	

					Board Noumenon	HF L.P.		件 号	
更 改	处 数	文 件 号	签 字	日 期					
设 计					Material: Q235 (>235Mpa)	数 量		共 张	
校 核						比 例		第 张	